

# شیر پروانه‌ای رادیاتور DN 80

## Radiator Butterfly Valve

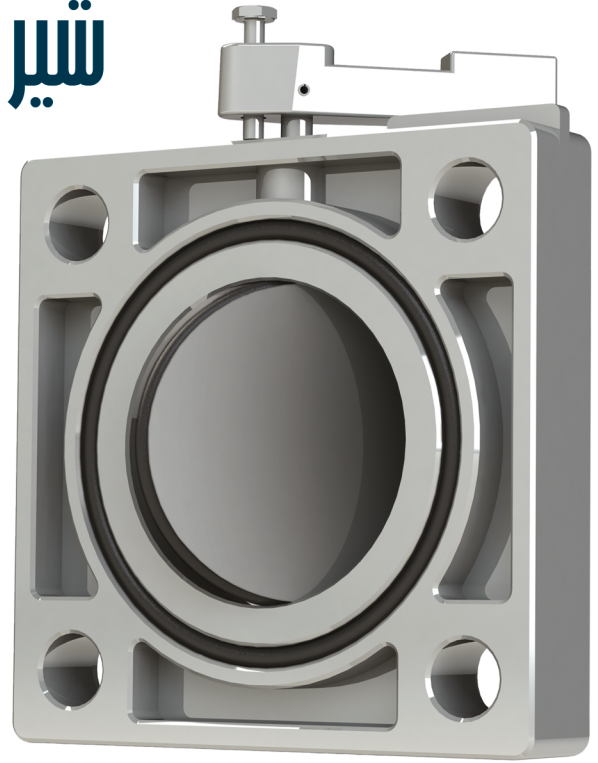

- These valves are designed for mounting between Flange of the transformer tank and radiator.
- All valves are tested for leakage and sealing.
- These valves are fixed to the transformer flanges using 4 M16 Bolts (the same bolts used for fixing the radiator).
- The indication of the direct operating direction is marked on the valve.

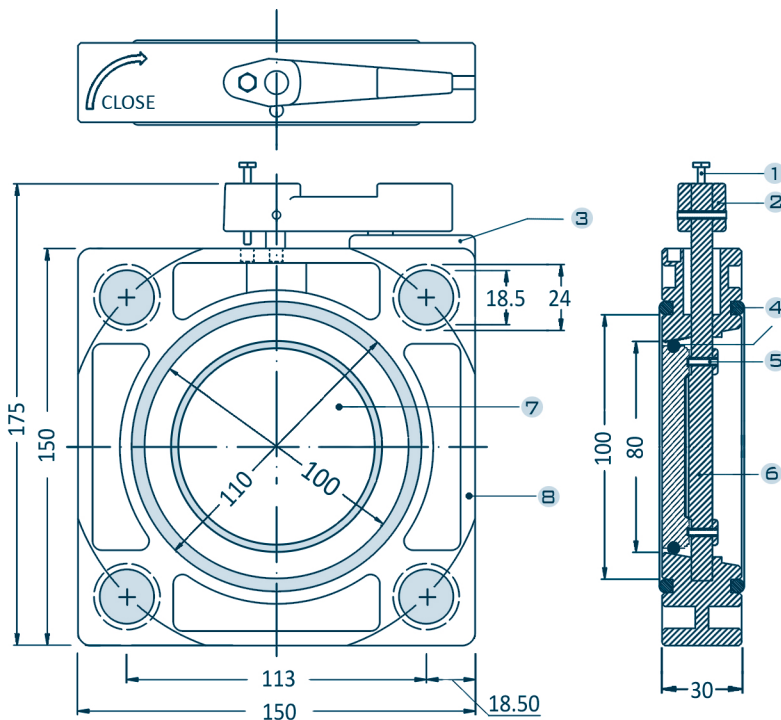

Part No.	DESCRIPTION	
1	Screw	M5-A2-70
2	Lever	Cast Aluminum
3	Stopper	Cast Aluminum
4	O-ring	NBR
5	Rivet	
6	Spindle	A2-70
7	Flap	Cast Aluminum
8	Valve body	Cast Aluminum

### TIGHTNESS TEST:

- A) With Oil Pressure Of 1 bar, 90°C, 30'
- B) With Air Pressure Of 2 bar (under water)

